

## Description

DLLCxxI-L a 3.3V~8V uni-directional TVS diode, utilizing leading monolithic silicon technology to provide fast response time and low ESD clamping voltage, making this device an ideal solution for protecting voltage sensitive high-speed data lines. The DLLCxxI-L has a low capacitance with a typical value at 1pF, and complies with the IEC 61000-4-2(ESD) standard with  $\pm 30\text{kV}$  air and  $\pm 30\text{kV}$  contact discharge. It is assembled into a lead-free SOD-323 package. The small size, low capacitance and high ESD surge protection make DLLCxxI-L an ideal choice to protect cell phone, wireless systems, and communication equipment.

## Mechanical Characteristics

- ◆ Package: SOD-323
- ◆ Lead Finish: Matte Tin
- ◆ Case Material: "Green" Molding Compound.
- ◆ UL Flammability Classification Rating 94V-0
- ◆ Moisture Sensitivity: Level 3 per J-STD-020
- ◆ Terminal Connections: See Diagram Below
- ◆ Marking Information: See Below

## Dimensions and Pin Configuration

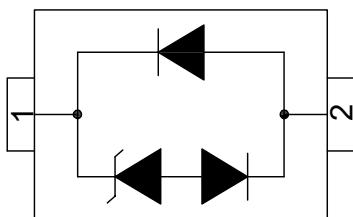

Circuit and Pin Schematic

## Features

- ◆ 150W peak pulse power (8/20 $\mu\text{s}$ )
- ◆ Ultra low capacitance : 1.0pF typical
- ◆ Ultra low leakage: nA level
- ◆ Low Operating: 3.3V,5V,8V
- ◆ Low clamping voltage
- ◆ Protects one power line or data line
- ◆ Complies with following standards:
  - IEC 61000-4-2 (ESD) immunity test
    - Air discharge:  $\pm 30\text{kV}$
    - Contact discharge:  $\pm 30\text{kV}$
  - IEC61000-4-4 (EFT) 40A (5/50ns)
- ◆ RoHS Compliant

## Applications

- ◆ USB Ports
- ◆ Smart Phones
- ◆ Wireless Systems
- ◆ Ethernet 10/100/1000 Base T

## Marking Information

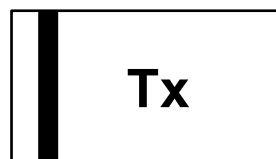

Tx: Device Marking Code

## Ordering Information

| Part Number | Marking | Packaging        | Reel Size |
|-------------|---------|------------------|-----------|
| DLLCxxI-L   | Tx      | 3000/Tape & Reel | 7 inch    |

### Absolute Maximum Ratings ( $T_A=25^\circ\text{C}$ unless otherwise specified)

| Parameter                       | Symbol           | Value       | Unit |
|---------------------------------|------------------|-------------|------|
| ESD per IEC 61000-4-2 (Air)     | V <sub>ESD</sub> | ±30         | kV   |
| ESD per IEC 61000-4-2 (Contact) |                  | ±30         |      |
| Operating Temperature Range     | T <sub>J</sub>   | -40 to +85  | °C   |
| Storage Temperature Range       | T <sub>stg</sub> | -55 to +150 | °C   |

### Electrical Characteristics ( $T_A=25^\circ\text{C}$ unless otherwise specified)

| DLLC031-L (Marking Code:T1) |                  |     |     |     |      |  |
|-----------------------------|------------------|-----|-----|-----|------|--|
| Parameter                   | Symbol           | Min | Typ | Max | Unit | Test Condition                         |
| Reverse Working Voltage     | V <sub>RWM</sub> |     |     | 3.3 | V    |  |
| Breakdown Voltage           | V <sub>BR</sub>  | 4   |     |     | V    | I <sub>T</sub> = 1mA                   |
| Reverse Leakage Current     | I <sub>R</sub>   |     | 1   | 100 | nA   | V <sub>RWM</sub> = 3.3V                |
| Forward Voltage             | V <sub>F</sub>   |     | 0.8 | 1.2 | V    | I <sub>F</sub> =10mA                   |
| Clamping Voltage            | V <sub>C</sub>   |     | 7   |     | V    | I <sub>PP</sub> = 1A (8 x 20µs pulse)  |
| Clamping Voltage            | V <sub>C</sub>   |     | 12  |     | V    | I <sub>PP</sub> = 10A (8 x 20µs pulse) |
| Peak Pulse Current          | I <sub>PP</sub>  |     |     | 10  | A    | t <sub>p</sub> =8/20µs                 |
| Junction Capacitance        | C <sub>J</sub>   |     | 1   |     | pF   | V <sub>R</sub> = 0V, f = 1MHz          |

| DLLC05I-L (Marking Code:T5) |                 |     |     |     |      |   |
|-----------------------------|-----------------|-----|-----|-----|------|---|
| Parameter                   | Symbol          | Min | Typ | Max | Unit | Test Condition                          |
| Reverse Working Voltage     | VRWM            |     |     | 5   | V    |   |
| Breakdown Voltage           | VBR             | 6   |     |     | V    | IT = 1mA                                |
| Reverse Leakage Current     | IR              |     | 1   | 100 | nA   | VRWM = 5V                               |
| Forward Voltage             | VF              |     | 0.8 | 1.2 | V    | IF=10mA                                 |
| Clamping Voltage            | VC              |     | 9   |     | V    | I <sub>PP</sub> = 1A (8 x 20μs pulse)   |
| Clamping Voltage            | VC              |     | 12  |     | V    | I <sub>PP</sub> = 8.5A (8 x 20μs pulse) |
| Peak Pulse Current          | I <sub>PP</sub> |     |     | 8.5 | A    | tp=8/20μs                               |
| Junction Capacitance        | CJ              |     | 1   |     | pF   | VR = 0V, f = 1MHz                       |

| DLLC08I-L (Marking Code:T8) |                 |     |     |     |      |                                       |
|-----------------------------|-----------------|-----|-----|-----|------|---------------------------------------|
| Parameter                   | Symbol          | Min | Typ | Max | Unit | Test Condition                        |
| Reverse Working Voltage     | VRWM            |     |     | 8   | V    |                                       |
| Breakdown Voltage           | VBR             | 8.5 |     |     | V    | IT = 1mA                              |
| Reverse Leakage Current     | IR              |     | 1   | 100 | nA   | VRWM = 8V                             |
| Forward Voltage             | VF              |     | 0.8 | 1.2 | V    | IF=10mA                               |
| Clamping Voltage            | VC              |     | 12  |     | V    | I <sub>PP</sub> = 1A (8 x 20μs pulse) |
| Clamping Voltage            | VC              |     | 12  |     | V    | I <sub>PP</sub> = 7A (8 x 20μs pulse) |
| Peak Pulse Current          | I <sub>PP</sub> |     |     | 7   | A    | tp=8/20μs                             |
| Junction Capacitance        | CJ              |     | 1   |     | pF   | VR = 0V, f = 1MHz                     |

**Typical Performance Characteristics (TA=25°C unless otherwise Specified)**

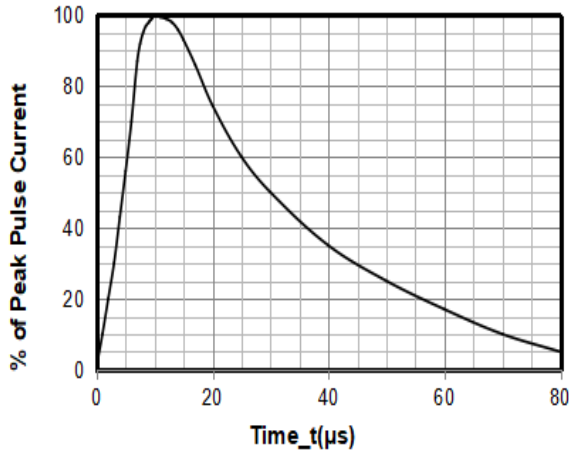

**8 X 20μs Pulse Waveform**

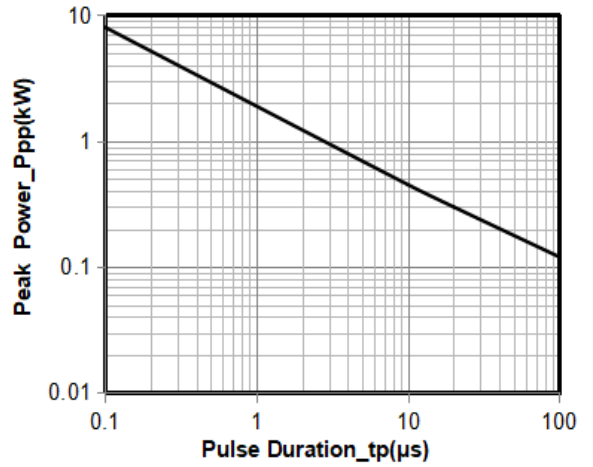

**Peak Pulse Power vs. Pulse Time**

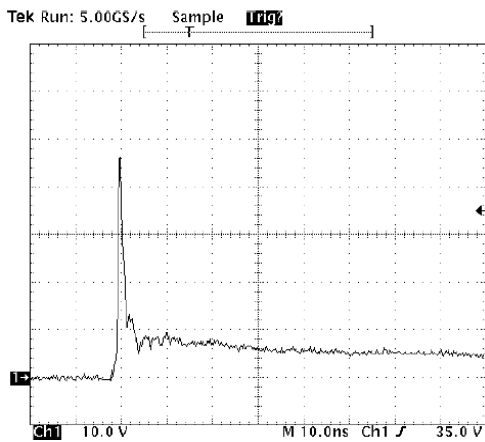

**Note: Data is taken with a 10x attenuator**  
**ESD Clamping Voltage**  
**8 kV Contact per IEC61000-4-2**

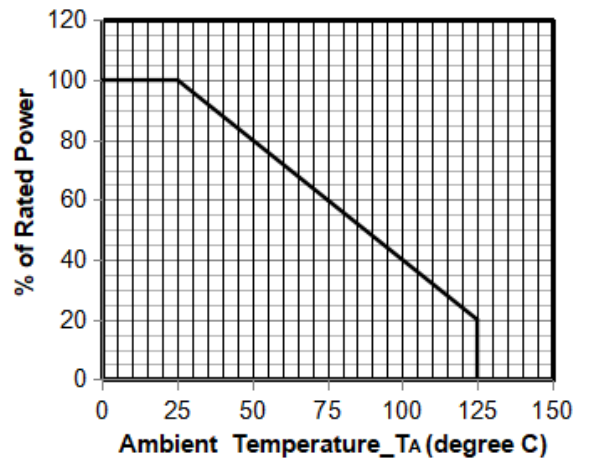

**Power Derating Curve**

## SOD-323 Package Outline Drawing

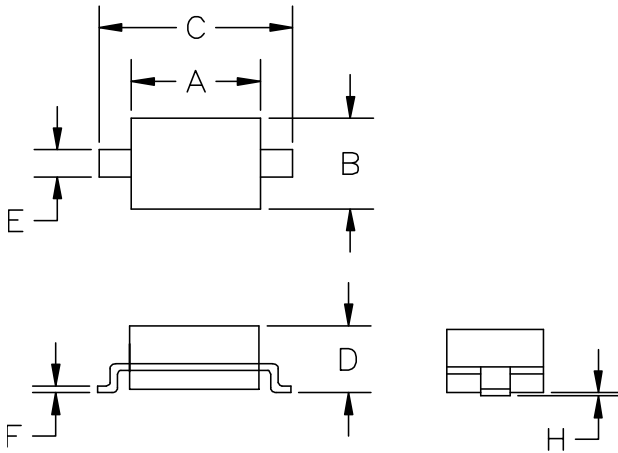

| SYM | DIMENSIONS  |      |        |       |
|-----|-------------|------|--------|-------|
|     | MILLIMETERS |      | INCHES |       |
|     | MIN         | MAX  | MIN    | MAX   |
| A   | 1.50        | 1.80 | 0.060  | 0.071 |
| B   | 1.20        | 1.40 | 0.045  | 0.054 |
| C   | 2.30        | 2.70 | 0.090  | 0.107 |
| D   | -           | 1.10 | -      | 0.043 |
| E   | 0.30        | 0.40 | 0.012  | 0.016 |
| F   | 0.10        | 0.25 | 0.004  | 0.010 |
| H   | -           | 0.10 | -      | 0.004 |

## Suggested Land Pattern

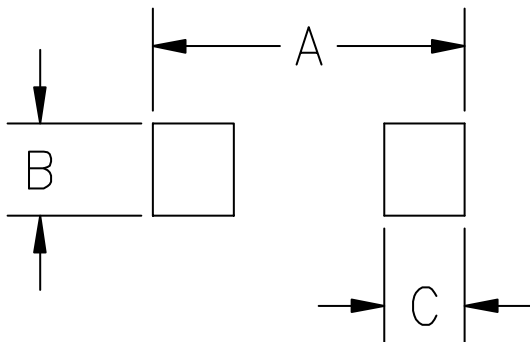

| SYM | DIMENSIONS  |        |
|-----|-------------|--------|
|     | MILLIMETERS | INCHES |
| A   | 3.15        | 0.120  |
| B   | 0.80        | 0.031  |
| C   | 0.80        | 0.031  |

## Contact Information

Changzhou D-first Electronics CO.,Ltd.

[www.first-electronic.com](http://www.first-electronic.com)

Email: [xhf@first-electronic.cn](mailto:xhf@first-electronic.cn)

Phone: +86 (0519) 8817 1671